



Owner
Manual

**The analogue
collection**

**circle
nanotube
a.c.t. two
a.c.t. 0.5
carbon
ply**

Please visit www.wilson-benesch.com
For electronic registration
of your avarantee.

Wilson-Benesch

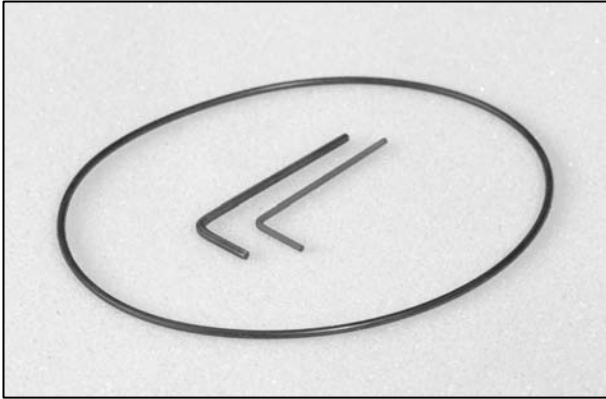

Circle Turntable Hardware Pack

Comprising: 1x Circle Drive Belt
1x 1.5mm Allen Wrench
1x 2.0mm Allen Wrench

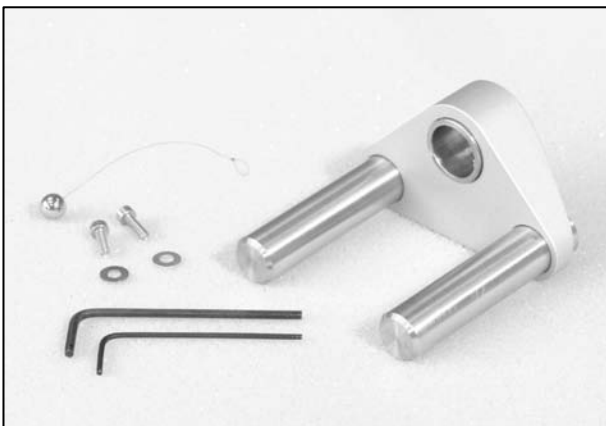

Tonearm Hardware Pack

Comprising: 1 x Counter-Balance Unit *
1 x Anti-Skate Weight *
1 x 1.3mm Allen Wrench
1 x 2.0mm Allen Wrench
2 x M3 Cartridge Washers
2 x M3 Cartridge Screws

* The nanotube's counterbalance and anti-skate weight comes pre assembled. Allen wrenches and cartridge screws are supplied as detailed above.

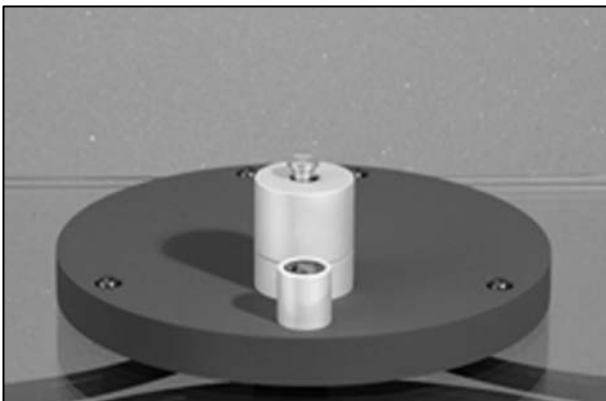

Step 1

Place the lower plinth in the desired location. This must be a perfectly horizontal surface that is free from vibration. Ideally this would be a pre-levelled audio table specifically designed for highly sensitive source equipment.

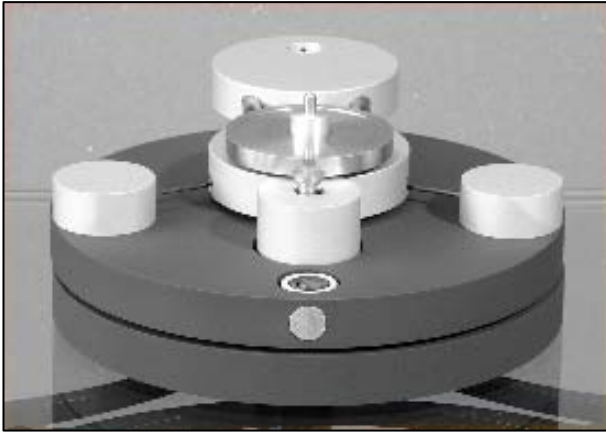

Step 2

Gently lower the upper plinth onto the lower plinth, taking great care not to knock the motor/pulley.

The motor and switch housings should not be in contact with the upper plinth. Ensure there is a gap between the plinth and these two parts.

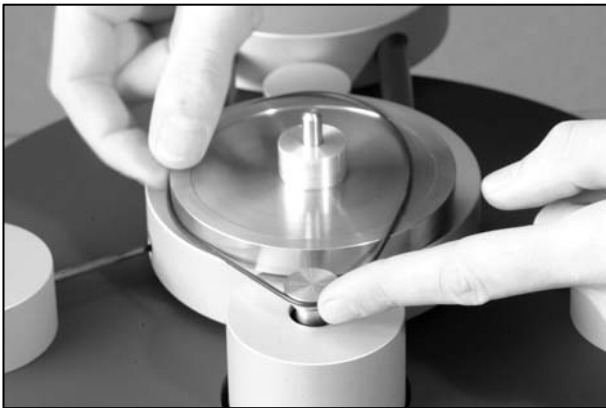

Step 3

Attach the belt by holding it in the pulley groove first. Then with the other hand, wrap the belt around the outside edge of the sub-platter.

When installing the drive belt, some concern for the belt should be shown, as it must be kept free of grease and dirt at all times. Once installed periodic cleaning of the belt should be considered good practice. The smaller groove on the pulley should be used for 33RPM and the larger groove for 45RPM.



Step 4

Place the acrylic platter onto the sub-platter making sure that it sits snugly on the stainless steel sub-platter. Switch on the motor and make sure everything runs smoothly before installing the tonearm on the turntable.

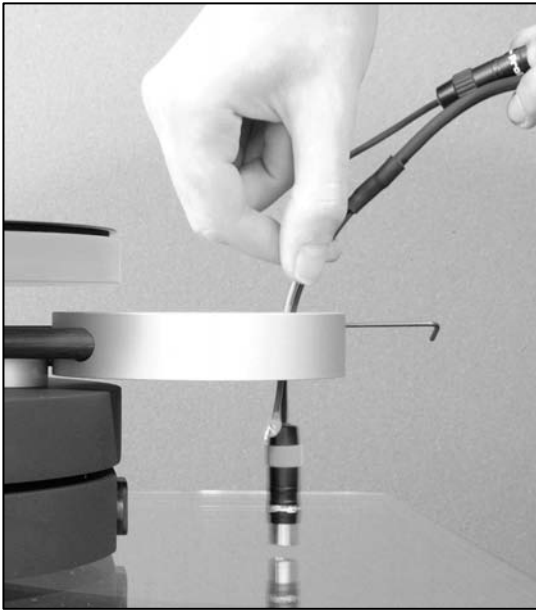

Step 5

Thread the tonearm lead through the hole in the arm board. This can only be achieved by threading one plug at a time.

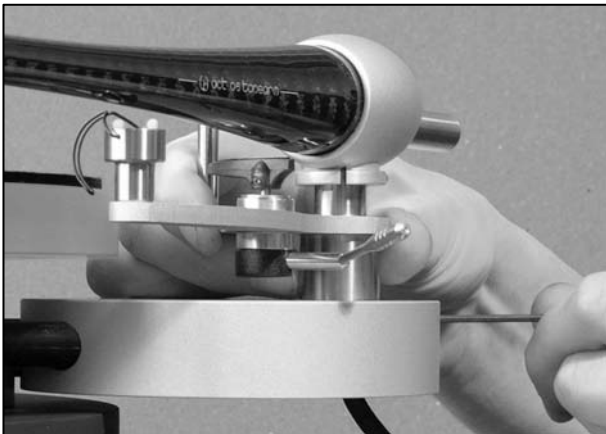

Step 6

Insert the tonearm stem into the arm board. Take note of the groove around the barrel of the stem. For the correct height, this groove should be just about visible when viewed from the side, in the plane of the upper surface of the arm board. The arm clamping screw can now be tightened using the supplied 2.0mm allen wrench inserted through the access hole to the rear of the arm board.

If you are fitting the tonearm to another turntable then the supplied arm collar will need to be fitted to the arm board of the turntable using the alignment gauge and geometry supplied on the next page.



Step 7

With the cartridge carefully removed from its packaging, you are now ready to attach it to the tonearm. Holding the cartridge by its body, offer it up to the four coloured plugs at the end of the tonearm. Simply slot each plug to its corresponding coloured pin. The pins are a fairly snug fit within the plugs so take care to control the necessary force. A slip at this stage could easily damage the cartridge.

Arm Positioning Procedure

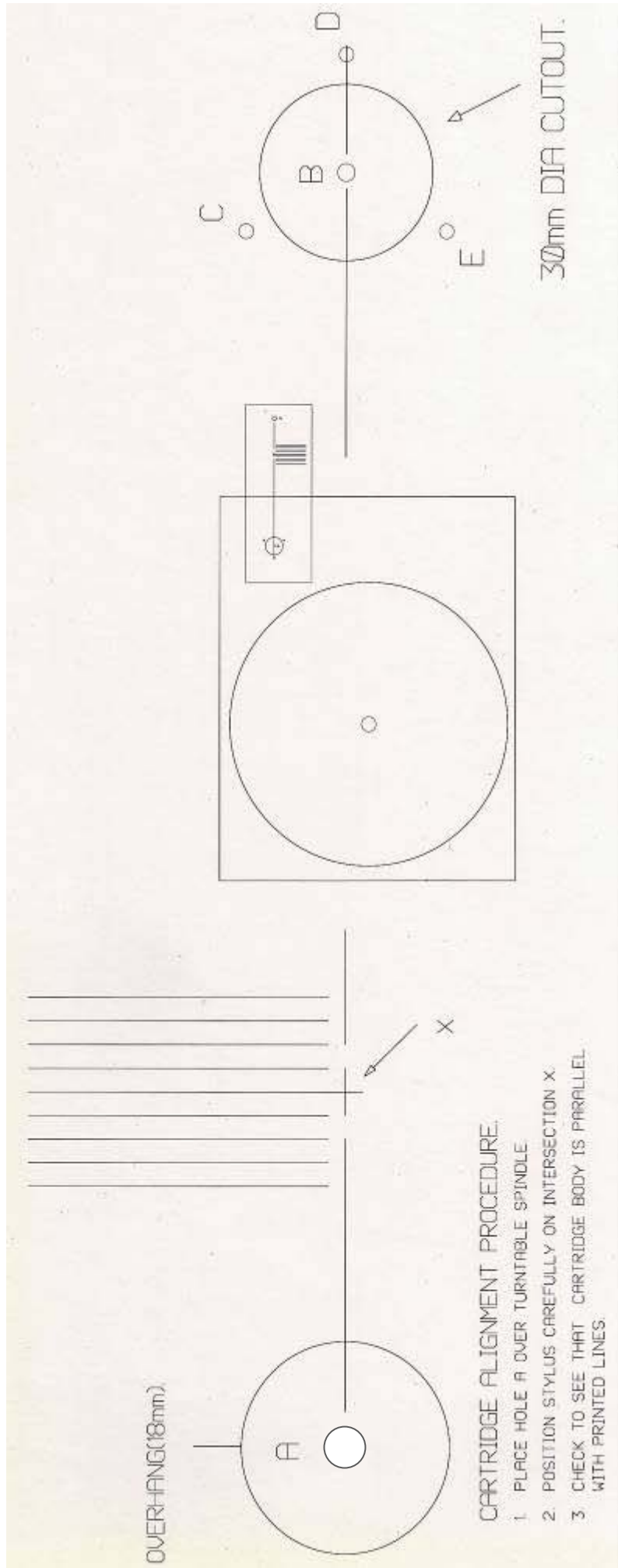

Wilson Benesch Tonearm Geometry (ACT 0.5, ACT Two, Nanotube)

Mounting Distance (Spindle to Pillar) = 217mm
 Effective Length = 235mm
 Overhang = 18mm

Fitting the Tonearm to other turntables varies according to each turntable's individual requirements. The mounting template with the above geometry, which is supplied with the tonearm, should be used to obtain the correct distance between the bearing centre and arm pivot.

A standard tonearm mount is available for mounting Wilson Benesch tonearms onto non-Wilson Benesch turntables.

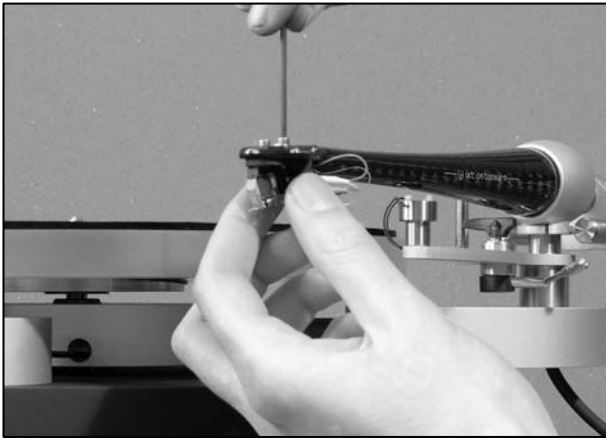

Step 8

With one M3 cartridge screw, inserted through one M3 washer in one hand, and the cartridge in the other. Thread the screw from above through one of the slots in the end of the tonearm. The end of this screw should then be screwed into the corresponding hole in the upper face of the cartridge body. You may find it easier to start the screw off by hand and then finish it off with the supplied 2.0mm allen wrench. Don't tighten the screw too firmly as you will be adjusting the cartridge position later. Repeat this process with the other screw.

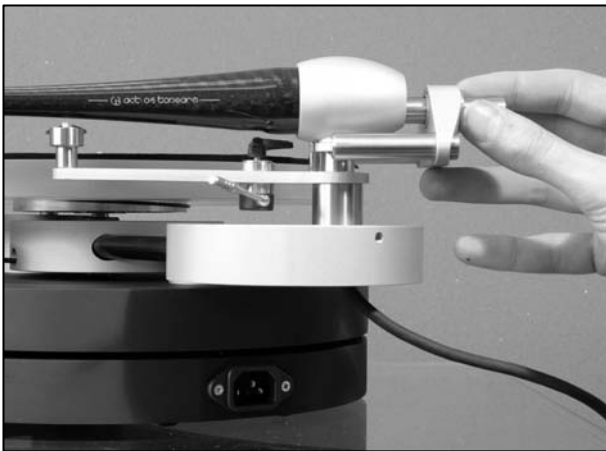

Step 9

If you are fitting an ACT 0.5 or ACT Two tonearm, when installing the counter-balance unit you will notice a small spring-loaded pin inside the main central hole. In order to engage this you must tilt the counter-balance back a little as you slide it onto the balance beam. Once the pin has passed the end of the beam, the Counter-Balance should straighten up and grip the beam sufficiently to be positioned where required. By rotating the counter-balance on the beam, fine adjustments of azimuth can be made.



Step 9 (Nanotube Only)

The Nanotube counter balance comes with the beam in place as part of the design and should be carefully screwed with the lightest of pressure. The grub screw is secreted on the side of the bearing housing that is out of view, adjacent to the anti-skate beam.

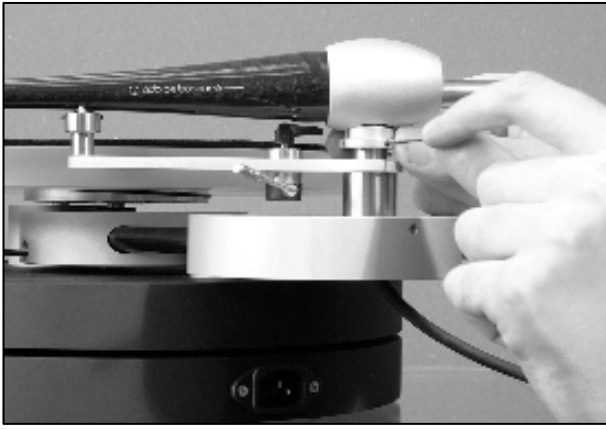

Step 10

At this stage the bearing can be made. This is done by unlocking and lowering the locking collar. Nip up the grub screw when the collar has been lowered onto the arm platform below.

Unlock the collar by inserting the supplied 1.3mm allen wrench in the screw at the side of the locking collar. While holding the bearing housing with one hand, unscrew the locking collar with the other and gently lower the bearing housing into position.

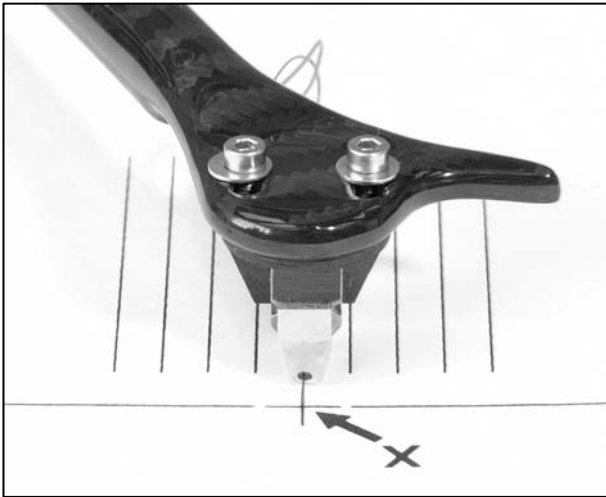

Step 11

With the cartridge alignment gauge/ shim in position, you can now begin to fine-tune the cartridge position. The first thing to do is to adjust the direction. With the needle tip placed at the cross marked 'X', the cartridge body should run parallel with the grid of lines on the gauge. The cartridge pins at the rear of the cartridge are a good indicator of direction and should aid you with this process.

Due to the way that the tonearm wire has been dressed in the Nanotube tonearm, it will require the platter to be removed before the next stage can be completed. This allows the arm park mechanism to be rotated to facilitate the setting of the cartridge over-hang.

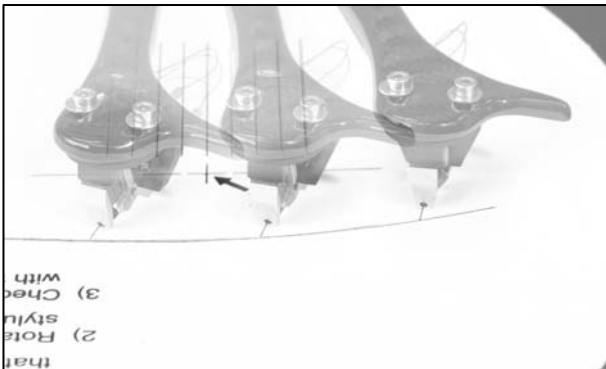

Step 12

The second adjustment related to cartridge position involves setting the distance between the needle tip and the tonearm pivot. This adjustment must be such that as the arm is moved across the alignment gauge, the needle tip tracks the printed arc. Once this has been adjusted, it is good practice to re-check Step 11. You may find it necessary to alternate between Steps 11 & 12 until you are satisfied with the cartridge position, before finally tightening the cartridge screws.

Do not over-tighten the screws, as the allen key will exert a lot of torque with relative ease so moderate finger pressure is more than adequate.



Step 13

If you are fitting an ACT 0.5 or an ACT Two tonearm, the anti skate is set as follows:

Each groove on the bias arm corresponds to an increase of 0.25 grams in cartridge weight (starting from the bearing housing as shown in the diagram below.). Therefore the correct position for the ply cartridge with a weight of 1.8grams is mid-way between the third and fourth grooves. The two rubber 'O' rings on the bias arm should grip the looped end of the thread to hold it in position. The remainder of the thread should then hang over the pulley, seated in the groove.

Step 13 (Nanotube Only)

If you are fitting a Nanotube One then a rule should be used to set the correct bias. the measurement should be taken from the near-side of the bearing housing or "egg" as shown in the table below.

The Thread should be held by the rubber O-rings to prevent the position changing.

ANTI SKATE POSITIONING (ACT Two & ACT 0.5)

ANTI SKATE POSITIONING (Nanotube)

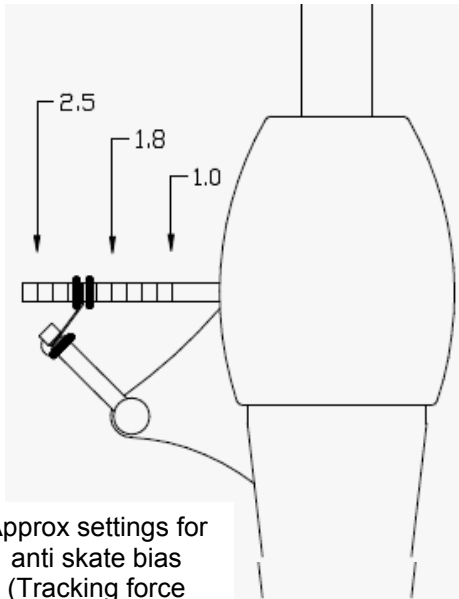

Approx settings for anti skate bias (Tracking force shown in grams)
shown in grams)

(Distance measured in mm from the side of the egg shaped bearing housing.)

- 8mm = 1g**
- 11mm = 1.25g**
- 14mm = 1.5g**
- 17mm = 1.75g**
- 20mm = 2g**
- 23mm = 2.25g**

GENERAL MAINTENANCE

The Full Circle system requires no adjustment or routine maintenance once it has been assembled. The synthetic lubricant in the bearing will last for tens of years without any need for changing. It will not evaporate or degrade like a mineral oil. Moreover the high precision bearing will be much less likely to be damaged by being taken apart, something that should be avoided. The Tonearm bearing requires no service and is a lifetime design. The motor is assembled using shell bearings that are not designed to withstand any on axis loading. Such a load will damage the bearings. Under normal circumstances the motor will last for tens of years. As long as the drive pulleys and belt are clean the stability and function of the system will be completely consistent year after year. To clean these items use a cleaning product like pure alcohol. This will remove any grease that may have built up from the atmosphere.

Wilson Benesch Analogue Product Guarantee

Wilson Benesch offers a two year conditional warranty to the end user. It is done in collaboration with our distributors.

The conditions of this warranty are:

- That Wilson Benesch receives the necessary registration details from the end user.
- That these details are received within six weeks of purchase.
- The warranty is only valid for the first owner and is not transferable.
- That it is limited to the repair of the equipment only.
- That any claim is accompanied by the necessary proof of purchase.
- That cover does not extend to damage caused by faulty or unsuitable ancillary equipment.
- That the serial number has not been altered, deleted, removed or made illegible.
- That the product has not been abused or modified in any way.
- That it was purchased originally from a Wilson Benesch authorised dealer.

The Wilson Benesch Full Circle

The Full Circle is a tribute to the medium of vinyl and it's unique position in the music lover's life. It has re-defined the way that analogue will evolve in the next century and eloquently re-affirms the long-term viability of the format.

The solution is comprised of three, State of the art components, the Circle turntable, A.C.T. 0.5 tonearm and Ply moving coil carbon fibre bodied cartridge. With a set up time of less than one hour, the complete product requires no "tuning" and will remain stable and reliable indefinitely.

Wilson Benesch is the world's foremost authority on the use and function of advanced composite structures when applied in audio systems. Over ten years of research and development lie behind this imaginative and unique product.



The Circle

- Advanced materials used throughout.
- Totally unique design concept.
- Low mass design.
- Immensely stiff unidirectional carbon fibre rods used in the principle structural components.
- High tolerance phosphor bronze plain bearing with tool steel spindle.

The Ply (moving coil cartridge)

- The ply is the perfect starting point for the circle, complementing as it does the advanced materials technology used in both the tonearm and the turntable.
- The Ply is a derivative of the Matrix cartridge.
- The ply is sold as part of the Full Circle Package.
- The maintenance costs are excellent.
- The net result is a robust design that provides no unnecessary frills. What is achieved is maximum performance at a highly competitive price.

Physical

Stylus Tip Type	Nude elliptic diamond
Stylus Tip Radius	7.6/17.7 micro millimetre
Cantilever	Solid boron
Coil Former	Pure iron
Coil	Copper
Body	Solid woven carbon fibre
Thread	2.5 mm
V.T.A.	20 Degrees
Weight	6 gms

Dynamics

Dynamic Comp	15 uM / Mh
--------------	------------

Electrical

Output Voltage	Low 0.58mV High 1.58mV
Coil Impedance	25 ohms
Freq Response	10-50 KHz
Channel Balance	Better than 0.5 db

System Matching Parameters

Resistive Load	10 – 47k ohms
Tracking Force	1.8 - 20 gms
Arm V.T.A.	Horizontal

The A.C.T. 0.5 – tonearm

The A.C.T. 0.5 tonearm is derived from the Wilson Benesch A.C.T. Two. The fundamental design features of the A.C.T. 0.5 tonearm are exactly the same as the A.C.T. Two. Wilson Benesch tonearms are quite unlike any other tonearm design in every respect.

- Torsionally 10 times stiffer than titanium.
- Half the mass of aluminium.
- 5 times the specific stiffness of steel.
- Order of magnitude better damping than most engineering metals.
- Unique curved carbon fibre arm tube.
- Unique Kinematic bearing.
- Exhibits stiction free operation.
- Will last indefinitely.
- Each one sounds the same.
- Unaffected by temperature.
- Dynamic damping is a natural function of the design.
- High-pressure contact points between all moving surfaces.
- Unique counterbalance arrangement.
- Provides non-compliant counter mass.
- Provides azimuth adjustments.
- Provides bearing stabilisation.
- Unique sound unlike any metal, conventional, product.

EFFECTIVE MASS	9g	OVERHANG	18mm
EFFECTIVE LENGTH	235mm	MOUNTING DISTANCE	217mm
WEIGHT	340g	CARTRIDGE RANGE	5g - 16g
INTERNAL WIRE	Silk Covered Litz Wire		
EXTERNAL WIRE	Star Quad 4 * 96 * 0.05 Resseun Shield.		
	Core to Core 70pf Resistance 0.108 Ohms.		
	Termination Gold plated RCA Phono Plugs.		

The Wilson Benesch A.c.t. two Tonearm

The A.C.T. Two

In the award winning ACT Two, Advanced Composite Technology is used to create the lightest, stiffest, most highly damped tube on the market that is almost 15% lower in mass than the ACT 0.5. The ACT Two provides all the technically proven virtues of the ACT 0.5 but in a more refined package.

The ACT Two is further testimony to our single minded commitment to the analogue medium and is a worthy addition to the Wilson Benesch product range.

Arm Tube

Wilson Benesch Ltd was the first company in the world to produce a fully moulded, single component arm tube. Torsionally, it is typically ten times stiffer than conventional arm tubes. It is three times stiffer in bending and an order of magnitude better at damping audio frequencies. Carbon fibre is unquestionably ideal for this function. The structure is formed from two contra rotating helixes of pure carbon fibre, much the same as some of the most effective natural structures which have benefited from millions of years of design refinements.



The shape of the beam is also quite natural as it has been determined precisely by its function and physical limits, rather than by the crudities of a manufacturing process as in the case of metals or ceramics. As a result, material use is exact and exists only where it is required. It should be noted that this is quite different from the mass produced straight carbon fibre tubes being used in other designs.

The performance of the carbon beam is matched by the equally effective and equally unique Kinematic bearing. The combined function of the bearing and counterbalance provides the ideal mechanism for a tonearm movement. The benefits of this technology for the end user are significant. All aspects of reproduction are improved as the cartridge is provided with the opportunity for the first time to do its job without being heavily influenced by the function of the system designed to support it.

Kinematic bearing

The bearing system of the ACT 0.5 and ACT Two tonearms is unique, although its operation is derived from a long established engineering principle, namely Kinematic location. Basically, the theory of Kinematics states that there are just six types of motion that a body can experience. Movement in the three axis of our three dimensional world and rotation in each of these axes. These motions are known as the six degrees of freedom. To fix a body in space one must prevent movement in each of these.

The kinematic bearing system allows just two degrees of freedom, rotation about one axis to track the record and rotation about a second axis, to allow for any vertical movement of the cartridge. All linear motions are completely eliminated, thus giving the cartridge a super stable reference from which to carry out its task as a measuring instrument. Indeed the classic application of Kinematics is in the design of high precision laboratory measuring equipment.

The bearing is stabilised by the low-slung counterbalance beams that eliminate radial movements of the tube. The simple design also permits fine adjustments of azimuth. A single point of contact between the counterbalance and beam is provided by four carbon chrome balls, thereby, avoiding troublesome resonance from a compliant type of mounting. The whole system is simple and reliable; there is no need for adjustment; it is unaffected by temperature change; pre-loading is no longer a concern; damping is catered for; the whole component functions without any noise. It will perform as well in thirty years time as it does today! It is important to note that neither a ballrace nor a uni-pivot can claim to satisfy the requirements of Kinematic location or indeed the other advantages incorporated into this deceptively simple solution.

ACT 0.5 & ACT TWO TONEARM ELEMENTS DIAGRAM

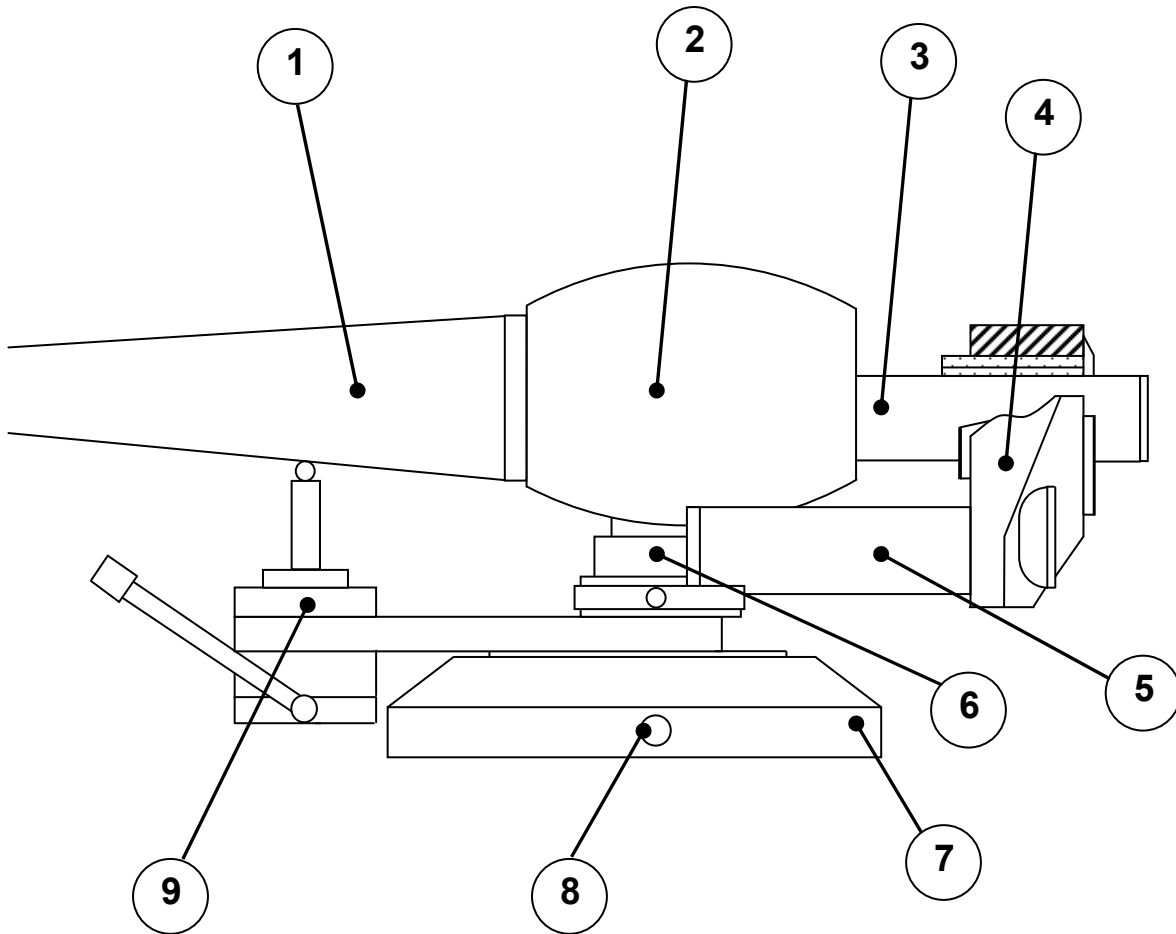

1. Helix of 0 / 90 woven carbon fibre moulded into headshell in one piece.
2. Bearing housing arm termination counterbalance location and pivot point location.
3. Low mass fixed counterbalance beam.
4. Spring loaded directly coupled Counter Balance / Azimuth adjustment.
5. Mass out riggers.
6. Bearing collar. This should lock the bearing for transport or during cartridge changes. Release to plate below to make the bearing when the arm is in use.
7. Precision arm board directly coupled through ball bearing locking system.
8. V.T.A. locking screw.
9. Lift Lower Mechanism

ACT 0.5 & ACT TWO TONEARM TECHNICAL INFORMATION

EFFECTIVE MASS	9g
OVERHANG	18mm
EFFECTIVE LENGTH	235mm
MOUNTING DISTANCE	217mm (<i>spindle to pillar</i>) – see page 4 for mounting template
WEIGHT	340g
CARTRIDGE RANGE	5g - 16g (<i>assuming a max required tracking force of 2g</i>)
INTERNAL WIRE	Silk Covered Litz Wire
EXTERNAL WIRE	Star Quad 4 * 96 * 0.05 Resseun Shield. Core to Core 70pf Resistance 0.108 Ohms. Termination Gold plated RCA Phono Plugs.

The Wilson Benesch Nanotube Tonearm

The Nanotube is a tonearm that defies belief. The structural performance of the A.C.T. Series of tonearms, have set the standard in terms of stiffness to weight ratio, as well as damping, since their introduction 17 years ago.

The Nanotube is much more complex. The tube is derived from the ideal natural form, of a hyperbolic curve, and so places the material, in exactly the place where the beam requires it to be, in order to achieve the stiffest structure, with the least amount of material. The tube itself, is composed of a woven helix of carbon fibre, to provide the stiffest torsional strength and the most damping, from the billions of carbon fibre filaments. Further localised stiffening, has been determined by computer modeling. Super high modulus uni-directional fibres, are deployed in these regions, adding immense stiffness with virtually no additional mass. The Epoxy resin matrix is then enhanced with nanotubes. After its creation, the tube is improved still further by the addition of low mass, high compression internal bulkheads.



These enhance tube stiffness and also provide high performance, cross axial damping. The internal wire is isolated by these structures also, providing the ideal disposition for the low level signals. No additional finishing is added to the tube for aesthetic considerations as this would add mass that has no sonic benefit. The result sees a structure that is more than an order of magnitude superior to its predecessors in terms of stiffness and damping. An amazing achievement given the previous benchmark, which in our opinion, was already more than several orders of magnitude superior to any metal or ceramic design!

The Nanotube benefits from other research results, that make the whole system less audible as well as more user friendly. The counter balance looks similar to its predecessor but has been totally redeveloped. It now sees a two stage compliant mounting to thwart any potential resonance in the metal and carbon structures from which it is created. The mass of the counter balance has also been optimised so as to match exactly the requirements of the Wilson Benesch carbon fibre cartridges. A small collection of other metal structures have been replaced by carbon fibre also, including all the anti skate systems. V.T.A. is also now fully adjustable to one, one hundredth of a millimetre.

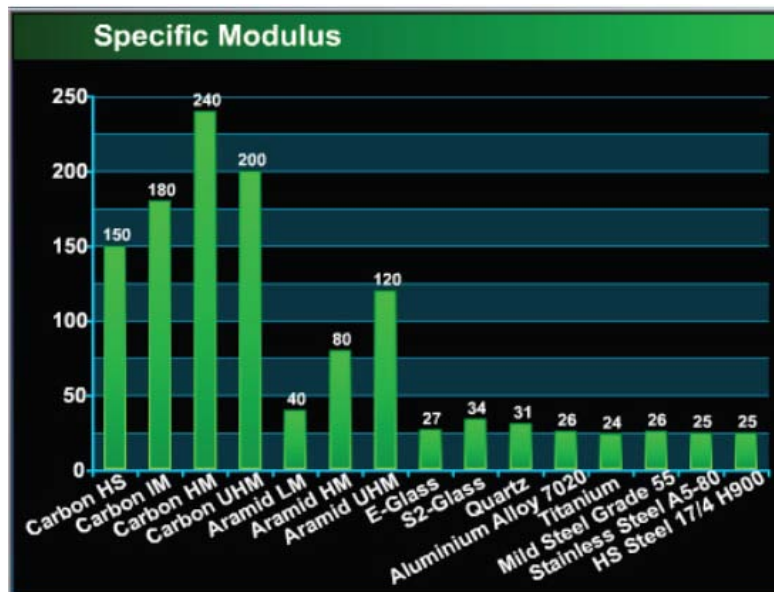

Carbon

The adjacent graph clearly shows the difference in stiffness, between the basic carbons and metals. Significantly, simply by adding nanotubes, improvements in stiffness, in the order of 30% can be achieved. Nano tubes are structures that are measured at the molecular level.

Typically, carbon is twenty five times smaller in diameter than a human hair. In each bundle that you see in a carbon fibre sheet, there are 25,000 fibres. In the A.C.T. tonearm there are literally billions of energy consuming boundaries! In the Nanotube Tonearm, damping and stiffness is being dramatically enhanced, it is thought, by cross-linking at the molecular level.

Nanotube Tonearm Elements Diagram

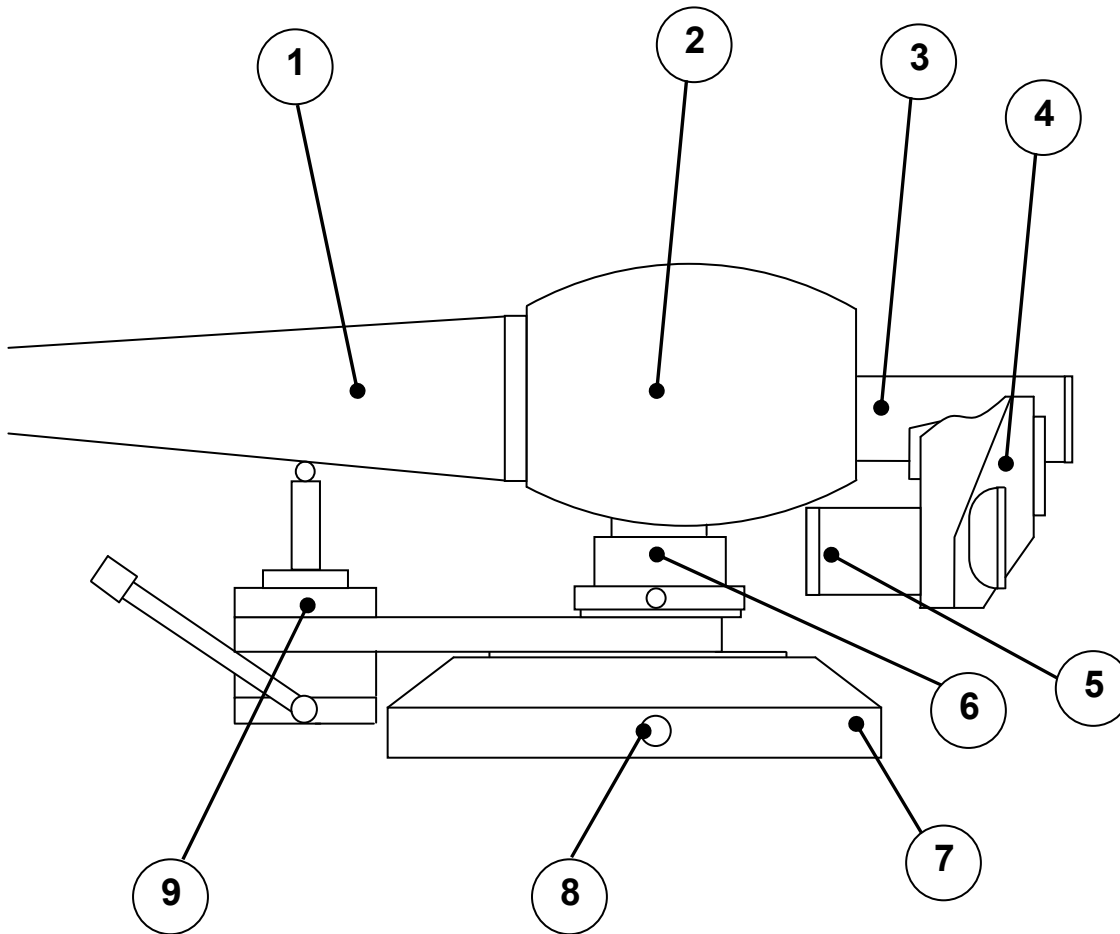

1. Helix of 0 / 90 woven carbon fibre moulded into headshell in one piece.
Enhanced by U.D. carbon fibre and nano technology epoxy resin and internal high compression foam bulkheads.
2. Bearing housing arm termination counterbalance location and pivot point location.
3. V.T.A. precision adjustment ring adjustable on the fly to one 100 mm per division.
4. Decoupled high mass low inertia counter weight / azimuth adjustment system.
5. Tungsten out riggers.
6. Bearing collar. This should lock the bearing for transport or during cartridge changes. Release to plate below to make the bearing when the arm is in use.
7. Precision arm board directly coupled through ball bearing locking system.
8. V.T.A. locking screw.
9. Lift Lower mechanism.

NANOTUBE TONEARM TECHNICAL INFORMATION

EFFECTIVE MASS	8g
OVERHANG	18mm
EFFECTIVE LENGTH	235mm
MOUNTING DISTANCE	217mm (<i>spindle to pillar</i>) – see page 4 for mounting template
WEIGHT	340g
CARTRIDGE RANGE	Up to 10g (<i>assuming a required tracking force of 2g total 12g</i>)
INTERNAL WIRE	Silk Covered Litz Wire
EXTERNAL WIRE	Star Quad 4 * 96 * 0.05 Resseun Shield. Core to Core 70pf Resistance 0.108 Ohms. Termination Gold plated RCA Phono Plugs.

The Wilson Benesch Carbon Cartridge

The Carbon Cartridge

The Wilson Benesch cartridge range is distinctly different from all other cartridges in the world. Whilst conventional materials technology can be seen as the norm, in the Wilson Benesch range the principle structures are all manufactured from solid carbon fibre.

The Wilson Benesch Carbon is a unique and innovative product. It is manufactured to exacting tolerances from the finest and most advanced materials. By inhibiting the principle agents of distortion detectable in metal based cartridges, the Carbon excels in all aspects of reproduction.

The high modulus self damping, machined and press moulded carbon fibre components are quite unique in their capacity to liberate the cartridge from the effects of material borne resonance.

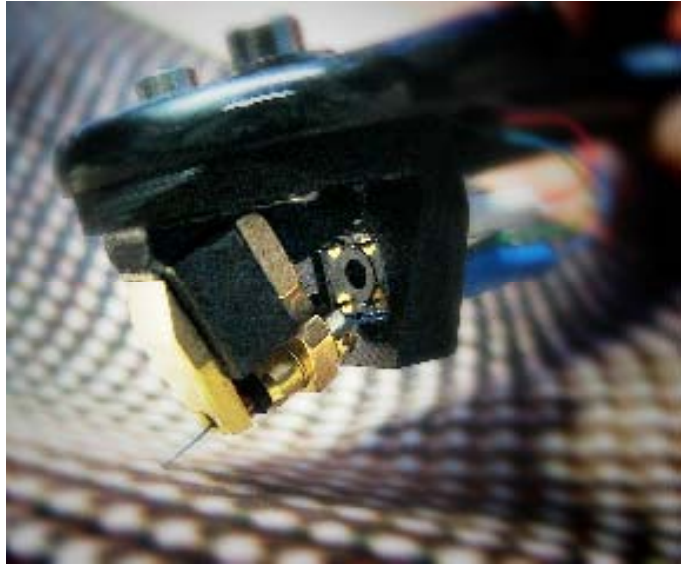

Specifications

Stylus tip type	Nude elliptic diamond
Stylus tip radius	7.6 / 17.7 micro millimetre
Cantilever	Solid Boron
Coil former	Pure sapphire
Coil	Copper
Body	Solid woven carbon fibre
Thread	2.5 mm
V.T.A	20 degrees
Weight	8 gms

Electrical

Output voltages	Low 0.58mV
Coil impedance	45 Ohms
Freq response	10 - 50 Khz
Channel balance	Better than 0.5 dB

Dynamics

Dynamic comp	15 uM / mN
--------------	------------

System matching parameters

Resistive load	10 - 47 K Ohms
Tracking force	1.8 - 2.0 gms
Arm V.T.A.	Horizontal

Thank you for buying Wilson Benesch

Wilson Benesch Ltd
Falcon House
Limestone Cottage Lane
Sheffield
S6 1NJ
UK

England Tel: +44(0) 1142 852656

Fax: +44(0) 1142 852657

Email: info@wilson-benesch.com

Web: www.wilson-benesch.com



Wilson Benesch Ltd

Falcon House, Limestone Cottage Lane, Sheffield, South Yorkshire, S6 1NJ, UK.

Tel: +44 (0) 114 285 2656 - Fax: +44 (0) 114 285 2657

Email: info@wilson-benesch.com - Web Address: www.wilson-benesch.com